



mavros



**Static Synchronous Compensator
Solution to Electrical Power Quality**

Introduction:

Electrical supply system in today's scenario faces a major challenge due to Power Quality issues.

- Harmonics on supply system due to Electronics type of loads that are used extensively.
- Power Factor correction, specifically with fast changing electrical loads and with unbalance loading between the three phases.
- Load unbalance between the three phases.

Such Power Quality "PQ" issues causes multiple undesirable issues.

- Reducing the efficiency of the electrical loads causing extra consumption, which in turn means extra money spent on electricity.
- Power Factor penalty increase and loss of Power Factor incentive in electricity billing.
- Maximum Demand factor in billing goes up. This again causes the electricity bills to go up.
- Overloading / Overheating of the supply system transformer, cables and switchgears due to enhanced skin effect and additional currents flowing in Neutral.
- Untimely failures / break-downs of the equipment connected to supply system. Causing Production loss / inconvenience.
- Unwarranted tripping of the supply system by triggering of protection relays without knowing the apparent cause.
- Disturbances in communication equipment.

No one would like to have such undesirable issues connected with their electrical supply system and there is a need to have a solution to take care of such undesirable phenomenon.

TAS PowerTek Pvt. Ltd. solution to all these problems is "**MAVROS**". A product commercially known as STATCOM – Static Synchronous Compensator is capable of giving you a hassle free environment with your Electrical supply system.

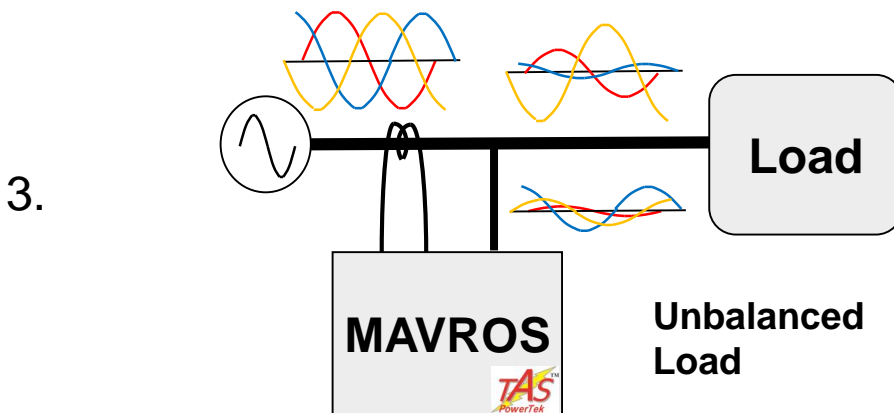
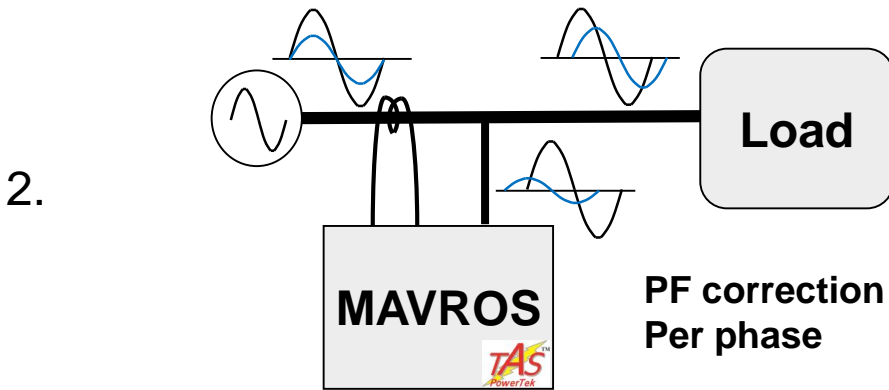
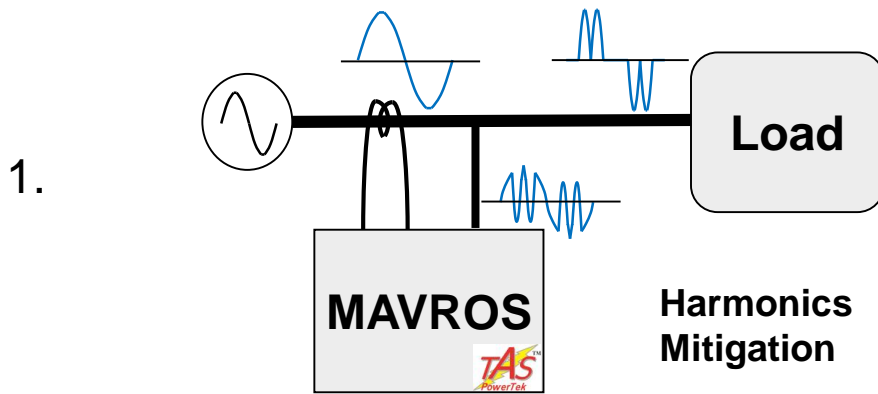

Above diagrammatic views shows the MAVROS method to improve the PQ aspects.

MAVROS Rating and Capacity:

Models available with AC RMS continuous current in three phases and Neutral from 15Amp to 300Amp.

Available Ratings: **15, 30, 60, 100, 150, 225 & 300 Amp AC RMS** in all the three phases and neutral on continuous basis.

Capacity enhancement with cascading of the multiple units up to 16 units with maximum current rating of overall multiple system as 4800 Amp. Units with **exclusive** selection for **PF correction** by usage of external Power Capacitors (with detuned reactors) can have **double the current** rating in same model. This mode can be revoked by User Setting menu.

Features:

- User selectable priority adjustment between Harmonics, PF correction and Load unbalance compensation.
- Selective harmonics filtering - Up to 9 selected Harmonics. User defined harmonic spectrum or with auto selection of highest harmonics on supply system.
- Reactive power compensation per individual phase – Enable/Disable with target PF setting from 0.7 Capacitive to 0.7 Inductive.
- Load Unbalance compensation- Enable/Disable with limit settings.
- Additional filter for reduced PWM ripple current (< 2% pk-pk)
- Closed loop control system for precise and effective compensation with high speed reaction time of < 300 μ S and response time of about one supply mains cycle.
- Unique Algorithm with current source pulse width modulation (PWM) giving high reliability of the operation to work under adverse supply PQ problems.
- Filtering efficiency > 94%.
- Wide range rating from 15Amp to 300 Amp in a single cubicle.
- Supports Modular master/slave configuration for expansion.
- Direct connection from 200 to 500V AC.
- Graphical colour LCD display for various electrical parameter information in text and graphical format. Displays harmonic spectrum bar graph and current waveforms (Load and source side)
- User friendly 7-keys keyboard for Display / Settings / Menu navigation and control.
- Communication module optionally available for SCADA system communication through various channels like RS-232, RS-485 (ModBus-RTU & ASCII), LAN (TCP-IP), GSM/GPRS, Wi-Fi.

Specifications:

Parameter	Values
Current Harmonics spectrum for measurement	Range 2 nd to 51 st Harmonic order
Current Harmonics spectrum for mitigation	Range 2 nd to 31 st Harmonic order
Maximum Harmonic frequencies for mitigation	9 harmonic frequencies individually selectable
Filtering efficiency	Better than 94% of filter KVA rating typically
Reaction time for compensation	<30μS instantaneous
Response time (compensation)	< 25mS typically (10% - 90% filtering)
Reactive power compensation	Dynamic with continuously variable
Target Power Factor Setting	0.7 Inductive to 0.7 capacitive
Load balancing	Line to Line balancing for Load Current within maximum 3% unbalance (KW unbalance).
Supply Voltage	220V to 484V ac Line Voltage – 50Hz / 60Hz
Output current PWM ripple (frequency range 8kHz to 36kHz)	<2% of unit rated current rating. Peak to peak.
Modularity	Up to 16 power units/filter. Power units can be master/slave
Current feedback CTs	Hall effect CT input.
Power Measurement Accuracy	Class 0.5
Harmonics spectrum mitigation levels (with only harmonics compensation mode selection), % of rated current of the system	3 rd : 75%, 5 th : 55%, 7 th : 40%, 9 th : 30%, 11 th : 23%, 13 th : 18%, 15 th : 15%, 17 th : 13%, 19 th : 11%, 21 st : 9%, 23 rd : 7%, 25 th : 6%, 27 th : 5%, 29 th : 4%, 31 st : 3%
Operating ambient temperature	0°C to 50°C
Altitude from sea level	Up to 1500 meters above sea level
IP class of enclosure protection	IP – 32
Humidity	10% to 90% RH
Galvanic Isolation (HV withstand)	2.5KVac for power and 1KVac for control
Supply Power Cable Entry	From bottom of the panel
Mounting Requirements	Solidly grouted or riveted on firm concrete base with provision for power cable entry
MAVROS Panel surrounding clearance	1.5 meter from front and Back. 0.5 meter from sides and top.
MAVROS Panel Colour	Light Grey

Working Principle:

MAVROS is a part of “FACTS” (Flexible AC Transmission System) family product range.

It is recommended to be installed with the electrical supply system where the Power Quality problems are already identified.

It is also important to know the overall effect of the problem to be resolved by usage of right rating of the system.

MAVROS defined current rating is the 100% current rating that can be sourced / synced into itself.

Connection diagram with supply system:

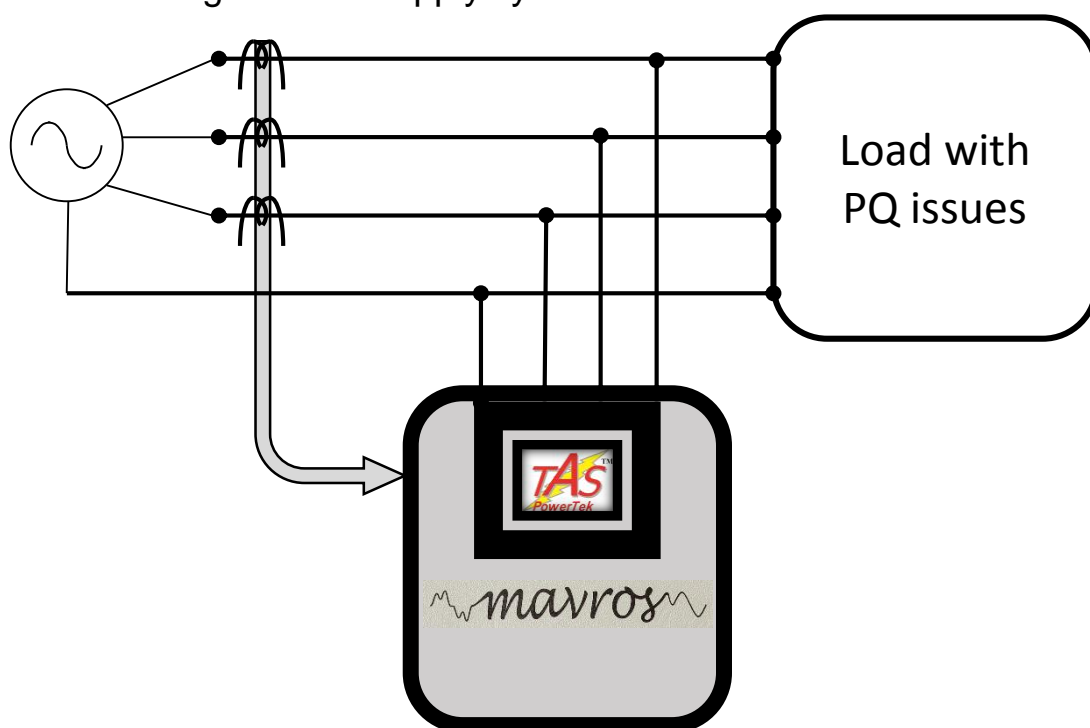

As can be seen from the connection diagram, the said unit is put in parallel with the Electrical Load with Power Quality issues. The said unit can be put in system in either 4-Wire (Ph-1, Ph-2, Ph-3, N) mode which is the most recommended mode or can be put in 3-Wire (Ph-1, Ph-2, Ph-3) mode wherein the Neutral is not connected.

Current feedback is taken from supply source side by usage of Current feedback devices. MAVROS unit accepts such feedback from Hall Effect sensors which has far better response for harmonics as compared to conventional magnetic CTs.

Working Principle:

MAVROS works by sourcing the right amount of disturbance / compensation current in reverse direction to filter it out from system.

It uses Power Electronics technology for creating the requisite mitigating current waveforms.

The control technology uses multiple DSP (Digital Signal Processing) microcontroller 32-bit and ARM cortex 32-bit microcontroller. This gives ultimate high speed processing power for complex algorithms embedded in the microcontroller chips.

Power section block diagram:

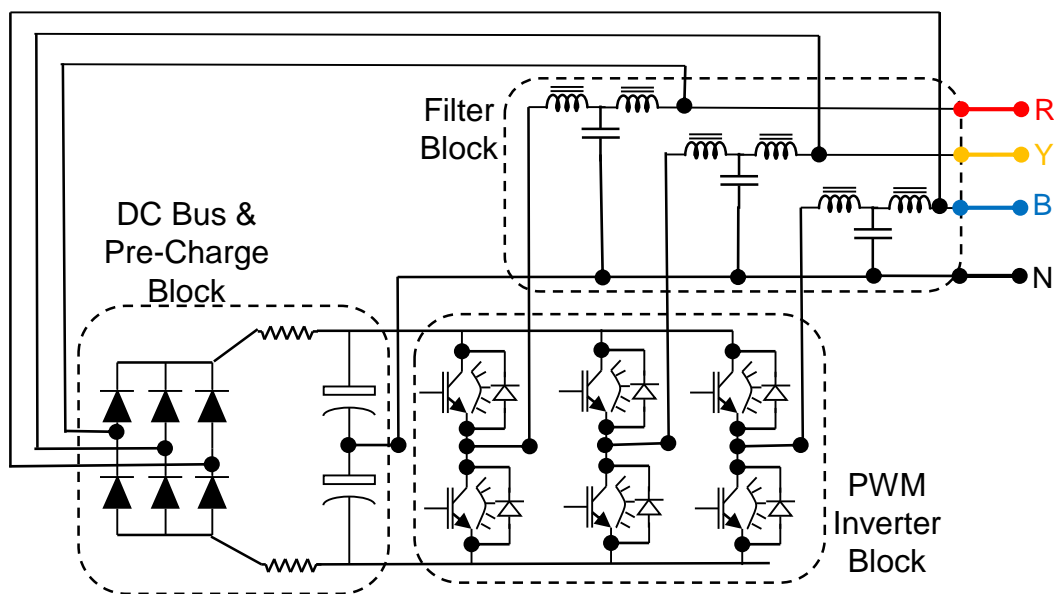

As can be seen from the diagram, the power section block is mainly made up of three broad blocks.

- **PWM Inverter Block:** It is an IGBT based inverter configuration which converts DC Bus power to PWM modulated AC current as per the required wave-shape.
- **DC Bus & Pre-Charge Block:** DC bus is typically 800Vdc and is buffered by high value electrolytic capacitors. For initial voltage controlled built up, pre-charge block that uses diode bridge converter with current limiting resistors.
- **Filter Block:** This block has primary function of creating the inductive reactive coupling between the inverter output and the supply lines. It also has functionality to control the high frequency ripple current that is generated by the PWM inverter.

Working Principle:

The control Electronics and Transducers sensors are specially designed for high reliability operation. Usage of multiple DSP microcontrollers gives this unit a very high processing speed and thus improves the response time.

Transducers are for getting information from various sections of the Power Block with high speed and accuracy. This information is processed by complex algorithms that are embedded into electronics.

Simplified Control Block Diagram is as:

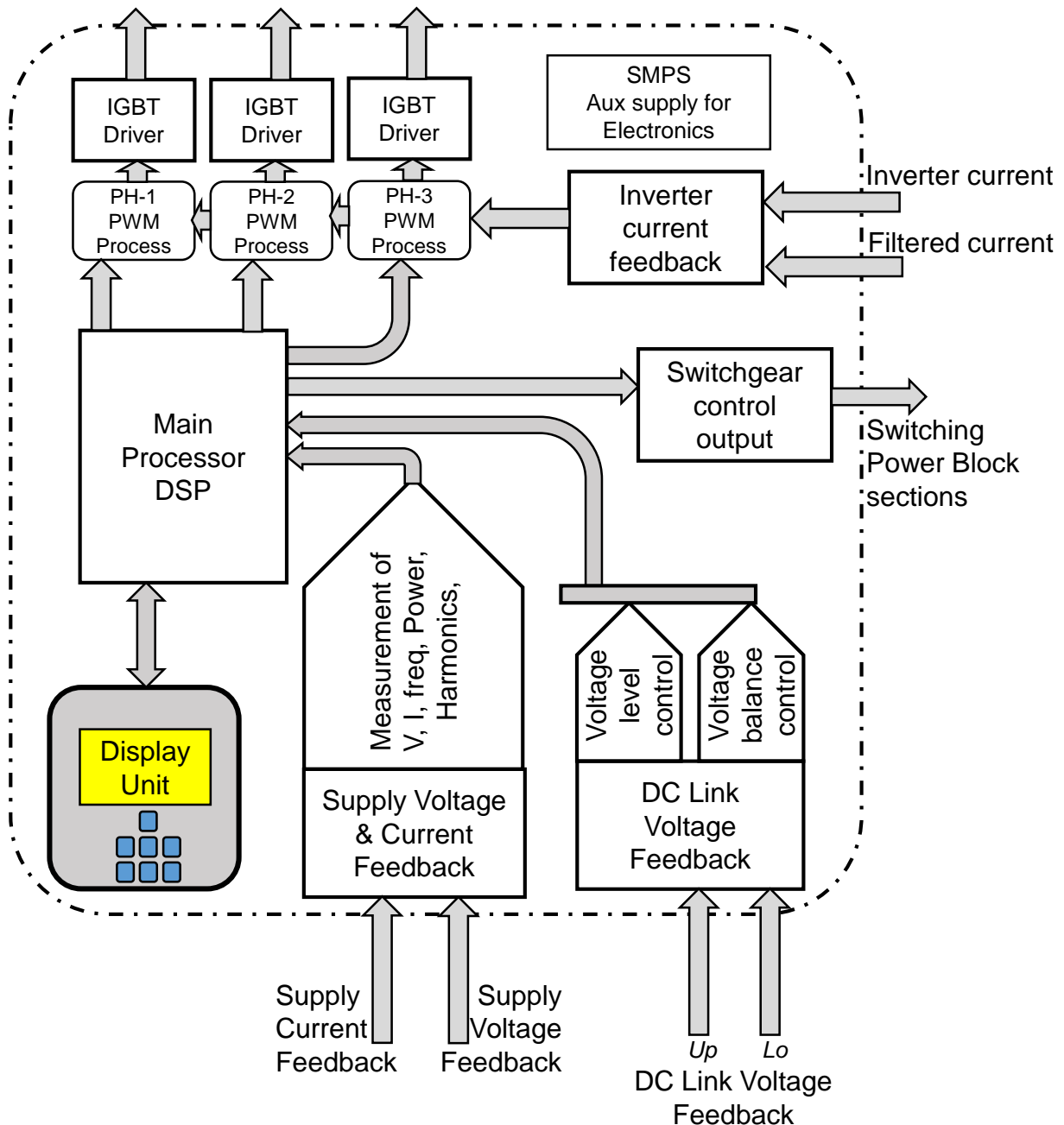



The Most assured way to forget your Electrical Supply System hassles.

TAS PowerTek Pvt. Ltd.

W-61, M.I.D.C., Ambad
Nasik-422010, M.S., INDIA.

Visit us at: <http://www.taspowertek.com>

Contact us on:

Tel: [+91 253 6694953...56](tel:+91253669495356)
sales@taspowertek.com
marketing@taspowertek.com